

8/11 kW

CENTURION® SERIES Residential Standby Generators Air-Cooled Gas Engine

INCLUDES:

- True Power™ Electrical Technology
- Two Line LCD Multilingual Digital Evolution™ Controller (English/Spanish/French /Portuguese)
- Two Transfer Switch Options Available:
50 Amp Pre-Wired Switch or
200 Amp Smart Switch.
See Page 4 for Details.
- Electronic Governor
- External Main Circuit Breaker,
System Status & Maintenance
Interval LED Indicators
- Sound Attenuated Enclosure
- Flexible Fuel Line Connector
- Composite Mounting Pad
- Natural Gas or LP Gas Operation
- 5 Year Limited Warranty
- Capability to be installed within 18" (457 mm) of a building*

Standby Power Rating

Model 006251-0 (Steel - Gray) - 8 kW 60 Hz
Models 006440-1, 006441-1 (Steel - Gray) - 11 kW 60 Hz



Note: CUL certification only applies to unbundled units and units packaged with pre-wired switches. Units packaged with the Smart Switch are UL certified in the USA only.

*Only if located away from doors, windows and fresh air intakes, and unless otherwise directed by local codes.

FEATURES

- **INNOVATIVE DESIGN & PROTOTYPE TESTING** are key components of GENERAC'S success in "IMPROVING POWER BY DESIGN." But it doesn't stop there. Total commitment to component testing, reliability testing, environmental testing, destruction and life testing, plus testing to applicable CSA, NEMA, EGSA, and other standards, allows you to choose GENERAC POWER SYSTEMS with the confidence that these systems will provide superior performance.
- **TRUE POWER™ ELECTRICAL TECHNOLOGY:** Superior harmonics and sine wave form produce less than 5% Total Harmonic Distortion for utility quality power. This allows confident operation of sensitive electronic equipment and micro-chip based appliances, such as variable speed HVAC systems.
- **TEST CRITERIA:**
 - ✓ PROTOTYPE TESTED
 - ✓ NEMA MG1-22 EVALUATION
 - ✓ SYSTEM TORSIONAL TESTED
 - ✓ MOTOR STARTING ABILITY
- **SOLID-STATE, FREQUENCY COMPENSATED VOLTAGE REGULATION.** This state-of-the-art power maximizing regulation system is standard on all Generac models. It provides optimized FAST RESPONSE to changing load conditions and MAXIMUM MOTOR STARTING CAPABILITY by electronically torque-matching the surge loads to the engine. Digital voltage regulation at ±1%.
- **SINGLE SOURCE SERVICE RESPONSE** from Generac's extensive dealer network provides parts and service know-how for the entire unit, from the engine to the smallest electronic component.
- **GENERAC® TRANSFER SWITCHES.** Long life and reliability are synonymous with GENERAC POWER SYSTEMS. One reason for this confidence is that the GENERAC product line includes its own transfer systems and controls for total system compatibility.

8/11 kW

Engine

- Generac (OHVI) design
Maximizes engine "breathing" for increased fuel efficiency. Plateau honed cylinder walls and plasma moly rings helps the engine run cooler, reducing oil consumption resulting in longer engine life.
- "Spiny-lok" cast iron cylinder walls
Rigid construction and added durability provide long engine life.
- Electronic ignition/spark advance
These features combine to assure smooth, quick starting every time.
- Full pressure lubrication system
Pressurized lubrication to all vital bearings means better performance, less maintenance and longer engine life. Now featuring up to a 2 year/200 hour oil change interval.
- Low oil pressure shutdown system
Shutdown protection prevents catastrophic engine damage due to low oil.
- High temperature shutdown
Prevents damage due to overheating.

Generator

- Revolving field
Allows for smaller, light weight unit that operates 25% more efficiently than a revolving armature generator.
- Skewed stator
Produces a smooth output waveform for compatibility with electronic equipment.
- Displaced phase excitation
Maximizes motor starting capability.
- Automatic voltage regulation
Regulates the output voltage to $\pm 1\%$ prevents damaging voltage spikes.
- UL 2200 listed
For your safety.

Transfer Switch

- Fully automatic
Transfers your vital electrical loads to the energized source of power.
- Pre-wired, color-coded conduits (Pre-wired switches only)
Ensures the easiest, trouble-free installation.
- DPM Technology (Smart Switch only)
Digital Power Management Technology allows for the smart control of two air conditioners without any additional items.
- Remote mounting
Mounts near your existing distribution panel for simple, low-cost

Evolution™ Controls

- Auto/Manual/Off illuminated buttons
Selects the operating mode and provides easy, at-a-glance status indication in any condition.
- Two-line LCD multilingual display
Provides homeowners easily visible logs of history, maintenance and events up to 50 occurrences.
- Sealed, raised buttons
Smooth, weather-resistant user interface for programming and operations.
- Utility voltage sensing
Constantly monitors utility voltage, setpoints 60% dropout, 80% pick-up, of standard voltage.
- Generator voltage sensing
Constantly monitors generator voltage to ensure the cleanest power delivered to the home.
- Utility interrupt delay
Prevents nuisance start-ups of the engine, adjustable 2-1500 seconds from the factory default setting of 5 seconds by a qualified dealer.
- Engine warm-up
Ensures engine is ready to assume the load, setpoint approximately 5 seconds.
- Engine cool-down
Allows engine to cool prior to shutdown, setpoint approximately 1 minute.
- Programmable exerciser
Operates engine to prevent oil seal drying and damage between power outages by running the generator for 12 minutes every other week. Also offers a selectable setting for weekly or monthly operation providing flexibility and lower fuel costs to the owner.
- Smart battery charger
Delivers charge to the battery only when needed at varying rates depending on outdoor air temperature.
- Electronic governor
Maintains constant 60 Hz frequency.

Unit

- Weather protective enclosure
Ensures protection against mother nature and can withstand winds up to 150 mph. Hinged key locking roof panel for security. Lift-out front for easy access to all routine maintenance items. Electrostatically applied textured epoxy paint for added durability.
- Enclosed critical grade muffler
Quiet, critical grade muffler is mounted inside the unit to prevent injuries.
- Small, compact, attractive
Makes for an easy, eye appealing installation, as close as 18" away from a building.
- SAE
Sound attenuated enclosure ensures quiet operation.

Installation System

- 1 ft (305 mm) flexible fuel line connector
Absorbs any generator vibration when connected to rigid pipe.
- Composite mounting pad
Eliminates the need to pour a concrete pad unless required by local municipalities.

8/11 kW

Generator

Model	006251-0 (8 kW)	006440-1, 006441-1 (11 kW)
Rated Maximum Continuous Power Capacity (LP)	8,000 Watts*	11,000 Watts*
Rated Maximum Continuous Power Capacity (NG)	7,000 Watts*	10,000 Watts*
Rated Voltage	240	240
Rated Maximum Continuous Load Current – 240 Volts (LP/NG)	33.3/29.2	45.8/41.7
Total Harmonic Distortion	Less than 5%	Less than 5%
Main Line Circuit Breaker	35 Amp	50 Amp
Phase	1	1
Number of Rotor Poles	2	2
Rated AC Frequency	60 Hz	60 Hz
Power Factor	1.0	1.0
Battery Requirement (not included)	Group 26R, 12 Volts and 525 CCA Minimum	
Unit Weight (lb/kg)	360/163	407/184.6
Dimensions (L x W x H) in/mm	48 x 25 x 29/1218 x 638 x 732	
Sound output in dB(A) at 23 ft (7 m) with generator operating at normal load**	62	63
Exercise Duration	12 min	12 min

Engine

	GENERAC OHVI	GENERAC OHVI V-TWIN
Type of Engine	GENERAC OHVI	GENERAC OHVI V-TWIN
Number of Cylinders	1	2
Displacement	410 cc	530 cc
Cylinder Block	Aluminum w/ Cast Iron Sleeve	Aluminum w/ Cast Iron Sleeve
Valve Arrangement	Overhead Valve	Overhead Valve
Ignition System	Solid-state w/ Magneto	Solid-state w/ Magneto
Governor System	Electronic	Electronic
Compression Ratio	9.5:1	9.5:1
Starter	12 Vdc	12 Vdc
Oil Capacity Including Filter	Approx. 1.5 qt/1.4 L	Approx. 1.7 qt/1.6 L
Operating rpm	3,600	3,600
Fuel Consumption		
Natural Gas	ft ³ /hr (m ³ /hr)	
1/2 Load	78 (2.21)	124 (3.51)
Full Load	121 (3.43)	195 (5.52)
Liquid Propane	ft ³ /hr (gal/hr) [l/hr]	
1/2 Load	31.6 (0.87) [3.29]	42.8 (1.18) [4.45]
Full Load	51.6 (1.42) [5.37]	70 (1.92) [7.28]

Note: **Fuel pipe must be sized for full load.** Required fuel pressure to generator fuel inlet at all load ranges - 3.5-7" water column (7-13 mm mercury) for natural gas, 10-12" water column (19-22 mm mercury) for LP gas. For Btu content, multiply ft³/hr x 2500 (LP) or ft³/hr x 1000 (NG). For Megajoule content, multiply m³/hr x 93.15 (LP) or m³/hr x 37.26 (NG).

Controls

2-Line Plain Text Multilingual LCD Display	Simple user interface for ease of operation.
Mode Buttons:	Automatic Start on Utility failure. 7 day exerciser.
Auto	
Manual	Start with starter control, unit stays on. If utility fails, transfer to load takes place.
Off	Stops unit. Power is removed. Control and charger still operate.
Ready to Run/Maintenance Messages	Standard
Engine Run Hours Indication	Standard
Programmable start delay between 2-1500 seconds	Standard (programmable by dealer only)
Utility Voltage Loss/Return to Utility Adjustable (Brownout Setting)	From 140-171 V/190-216 V
Future Set Capable Exerciser/Exercise Set Error Warning	Standard
Run/Alarm/Maintenance Logs	50 Events Each
Engine Start Sequence	Cyclic cranking: 16 sec. on, 7 rest (90 sec. maximum duration).
Starter Lock-out	Starter cannot re-engage until 5 sec. after engine has stopped.
Smart Battery Charger	Standard
Charger Fault/Missing AC Warning	Standard
Low Battery/Battery Problem Protection and Battery Condition Indication	Standard
Automatic Voltage Regulation with Over and Under Voltage Protection	Standard
Under-Frequency/Overload/Stepper Overcurrent Protection	Standard
Safety Fused/Fuse Problem Protection	Standard
Automatic Low Oil Pressure/High Oil Temperature Shutdown	Standard
Overcrank/Overspeed (@ 72 Hz)/rpm Sense Loss Shutdown	Standard
High Engine Temperature Shutdown	Standard
Internal Fault/Incorrect Wiring Protection	Standard
Common External Fault Capability	Standard
Field Upgradable Firmware	Standard

**Sound levels are taken from the front of the generator. Sound levels taken from other sides of the generator may be higher depending on installation parameters. Rating definitions - Standby: Applicable for supplying emergency power for the duration of the utility power outage. No overload capability is available for this rating. (All ratings in accordance with BS5514, ISO3046 and DIN6271). * Maximum wattage and current are subject to and limited by such factors as fuel Btu/megajoule content, ambient temperature, altitude, engine power and condition, etc. Maximum power decreases about 3.5 percent for each 1,000 feet (304.8 meters) above sea level; and also will decrease about 1 percent for each 6 °C (10 °F) above 16 °C (60 °F).

8/11 kW

Pre-Wired Switch Features

- Electrically operated, mechanically-held contacts for fast, positive connections.
- Rated for all classes of load, 100% equipment rated, both inductive and resistive.
- 2 pole, 250 VAC contactors.
- 30 millisecond transfer time.
- Single coil design.
- Main contacts are silver plated or silver alloy to resist welding and sticking.
- NEMA 1 (indoor rated) enclosure is standard on the pre-wired switch.
- Pre-wired 30 foot (9.1 meter) whip to connect to the provided 5 foot pre-wired whip and external connection box.
- Pre-wired 2 foot (0.61 meter) whip, color coded to connect into the existing electrical panel.

Model	006251-0 (8 kW)	006440-1 (11 kW)
No. of Poles	2	2
Current Rating (Amps)	50	50
Voltage Rating (VAC)	120/240, 1Ø	120/240, 1Ø
Utility Voltage Monitor (Fixed)*		
-Pick-up	80%	80%
-Dropout	60%	60%
Return to Utility*	approx. 15 sec.	approx. 15 sec.
Exercise weekly for 12 minutes*	Standard	Standard
UL Listed	Standard	Standard
Total of Pre-wired Circuits	10	12
No. 15 A 120 V	3	5
No. 20 A 120 V	3	3
No. 20 A 240 V	1	-
No. 30 A 240 V	1	1
No. 40 A 240 V	-	1
No. 50 A 240 V	-	-
Circuit Breaker Protected Available RMS Symmetrical Fault Current @ 250 Volts	10,000	10,000

*Function of Evolution Controller

Dimensions

Mechanical Dimensions*							
	Height			Width			Depth
	H1	H2	H3	W1	W2	W3	
in	18.5	22.5	22	10.5	15.4	14.4	3.8
mm	470	571.8	558.8	266.7	392	366	97.5

*Note: The 50 Amp switch is flush mountable. H1 and W1 refer to mounting hole spacing. H2 and W2 are cover dimensions. H3 and W3 (not shown in diagram) are the enclosure dimensions without cover.

Wire Ranges		
Conductor Lug	Neutral Lug	Ground Lug
1/0 - #14	2/0 - #14	2/0 - #14

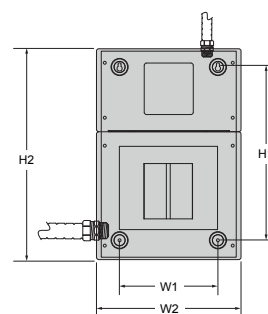

50 Amp Switch

Smart Switch Features

available on 11 kW model only

- Includes Digital Power Management Technology standard (DPM).
- Intelligently manages two air conditioner loads with no additional hardware.
- Up to four more large (120/240 VAC) loads can be managed when used in conjunction with Power Management Modules (PMM**).
- Electrically operated, mechanically-held contacts for fast, clean connections.
- Rated for all classes of load, 100% equipment rated, both inductive and resistive.
- 2 pole, 250 VAC contactors.
- Service equipment rated, dual coil design.
- Rated for both aluminum and copper conductors.
- NEMA/UL 3R aluminum outdoor enclosure.
- Main contacts are silver plated or silver alloy to resist welding and sticking.

**Note: PMM starter kit is required prior to using the modules.

Dimensions

	200 Amps 120/240, 1Ø Open Transition Service Rated					
	Height		Width		Depth	
	H1	H2	W1	W2		
in	27.24	30.0	11.4	13.5	7.09	
mm	692.0	762.4	289.0	343.0	180.0	

Model 006441-1 (11 kW)

No. of Poles	2
Current Rating (Amps)	200
Voltage Rating (VAC)	120/240, 1Ø
Utility Voltage Monitor (Fixed)*	
-Pick-up	80%
-Dropout	60%
Return to Utility*	approx. 13 sec.
Exercise weekly for 12 minutes*	Standard
UL Listed	Standard
Enclosure Type	NEMA/UL 3R
Withstand Rating (Amps)	22,000
Lug Range	250 MCM - #6

*Function of Evolution Controller

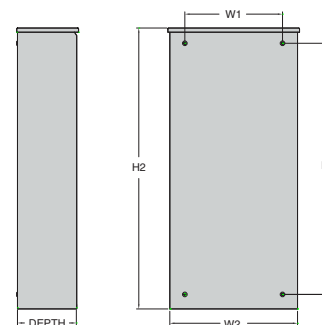

8/11 kW

Model #	Product	Description
006463-1	Mobile Link™	Mobile Link allows you to check the status of your generator from anywhere that you have access to an Internet connection from a PC or with any smart device. You will even be notified when a change in the generator's status occurs via e-mail or text message.
005819-0	26R Wet Cell Battery	Every standby generator requires a battery to start the system. Generac offers the recommended 26R wet cell battery for use with all air-cooled standby product excluding PowerPact®.
006212-0	Cold Weather Kit	If the temperature regularly falls below 32 °F (0 °C), a cold weather kit is required to maintain optimal battery and oil temperatures. Kit consists of a battery warmer and oil filter heater with built-in thermostats.
005621-0	Auxiliary Transfer Switch Contact Kit	The auxiliary transfer switch contact kit allows the transfer switch to lock out a single large electrical load you may not need. Not compatible with 50 amp pre-wired switches.
005666-0	Fascia Base Wrap Kit	The fascia base wrap snaps together around the bottom of the new air cooled generators. This offers a sleek, contoured appearance as well as offering protection from rodents and insects by covering the lifting holes located in the base.
005704-0	Paint Kit	If the generator enclosure is scratched or damaged, it is important to touch-up the paint to protect from future corrosion. The paint kit includes the necessary paint to properly maintain or touch-up a generator enclosure.
006482-0 - 8 kW 006483-0 - 11 kW	Scheduled Maintenance Kit	Generac's scheduled maintenance kits provide all the hardware necessary to perform complete routine maintenance on a Generac automatic standby generator.
006664-0	Wireless Remote Monitor	Completely wireless and battery powered, Generac's wireless remote monitor provides you with instant status information without ever leaving the house. Not compatible with Centurion ES systems.
006199-0	PMM Starter Kit	The PMM Starter Kit consists of a 24 VAC, field installed transformer that enables the use of the 24 VAC Power Management Modules (PMMs) and one PMM. The standard controller (without starter kit) can control two HVAC loads with no additional hardware. Not compatible with pre-wired switches.
006186-0	Power Management Module (50 Amps)	Power Management Modules are used in conjunction with the Smart Switch to increase its power management capabilities. It gives the Smart Switch additional power management flexibility not found in any other transfer switch. Not compatible with pre-wired switches. Note: PMM Starter Kit required.

dimensions & UPCs

Dimensions shown are approximate. Refer to installation manual for exact dimensions. DO NOT USE THESE DIMENSIONS FOR INSTALLATION PURPOSES.

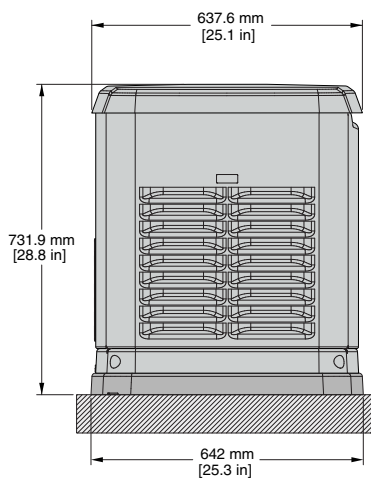

LEFT SIDE VIEW

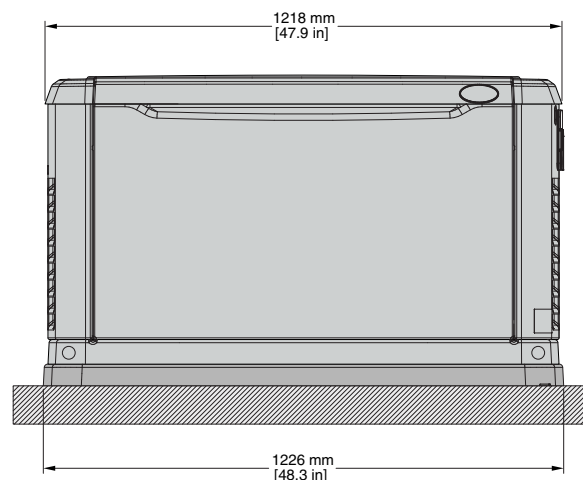

FRONT VIEW

Model	UPC
006251-0	696471062519
006440-0	696471064407
006441-0	696471064414